HAY MOISTURE TESTER HX-700



Operating Manual

HAY MOISTURE TESTER SAFETY ISSUES

Read these safety issues to avoid injury, material loss or other accidental damages.

The instrument is designed to be safe, but, nevertheless, be sure to use it only after reading these safety issues.

■ MAKE SURE TO OBSERVE THE SAFETY PRECAUTIONS.

Read all the safety precautions in this manual.

■ DO NOT USE THE INSTRUMENT IF A FAILURE HAS OCCURRED

Call for repair or service if a failure or a malfunction has been observed. Contact our service personnel.

■ GRAPHIC SYMBOLS FOR SAFETY

To prevent damage or harm from incorrect operation of the instrument, this manual contains various graphic symbols. The symbols concerned with safety issues are as follows.



CAUTION

Be sure to follow the instructions for safety reasons.

CONTANTS

1. FEATURES	4
2. SPECIFICATIONS	5
3. NOMENCLATURE	6
4. DISPLAY SCREEN	7
5. HOW TO USE THE INSTRUMENT	8
5-1. Preparation for measurement	8
5-2. How to measure	9
5-3. Precautions for measurement	11
5-4. Display of the average	12
5-5. How to set Continuous Measurement mode	13
5-6. How to correct the moisture % display	14
5-7. How to set the alarm	15
6. ERROR DISPLAY	16

1. FEATURES

Simply inserting the probe in the hay, dried or stored, allows this instrument to display moisture content in % by utilizing the electric resistance measurement. Very handy to use and easy to operate, it allows you to measure hay wherever and whenever you want to.

Damp hay in storage is apt to ferment or rot, and over drying will reduce the quality. The weight fluctuation of the hay due to water content is an important issue in business transactions.

HX-700 is a long, weighted instrument designed to match the needs of this industry. Make the most of the advantages offered to you by the HX-700, whether for moisture control during storage or to check moisture during a buying or selling transaction.

- **AUTO POWER OFF FUNCTION**

Turns the instrument power off automatically if not operated for 5 minutes.

- **ALARM SETTING INSTALLED**

Buzzer alarm can be set for high moisture at 10~39%.

- **WATER % CORRECTION INSTALLED**

Accepts a correction in moisture % from -9.9 to +9.9%

2. SPECIFICATIONS

Measurement method	: Electric resistance
Measurement object	: Hay (Grass)
Measurement range	: 8~30%
Measurement accuracy	: Standard error 1.0% (20% or under)
Standard method	: 135°C (275°F), 2hours
Display	: Digital (LCD, The smallest display digit is 0.1%)
Usable temperature	: 0°C~40°C (32F~104°F)
Special features	: Average display Upper alarm setting (10~39% or off) Automatic power off (in 5 minutes) Moisture % correction (-9.9 to +9.9%)
Power source	: 1.5V AA alkaline battery x 6
Dimension	: 110(W) x 210(D) x 50(H)mm
Weight	: 0.5Kg
Accessories	: Probe, Shoulder strap, Carrying case, 1.5V AA alkaline battery x 3, Operating manual

3. NOMENCLATURE

[Instrument body]

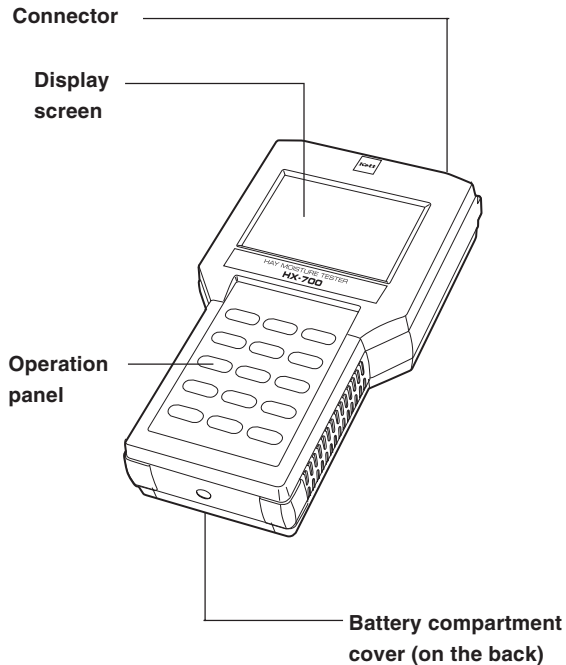

[Accessories]

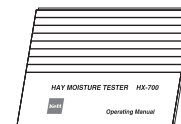
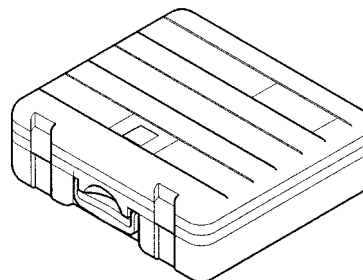
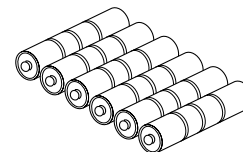
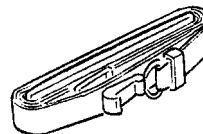
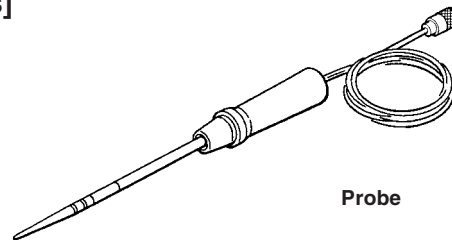

4. DISPLAY SCREEN

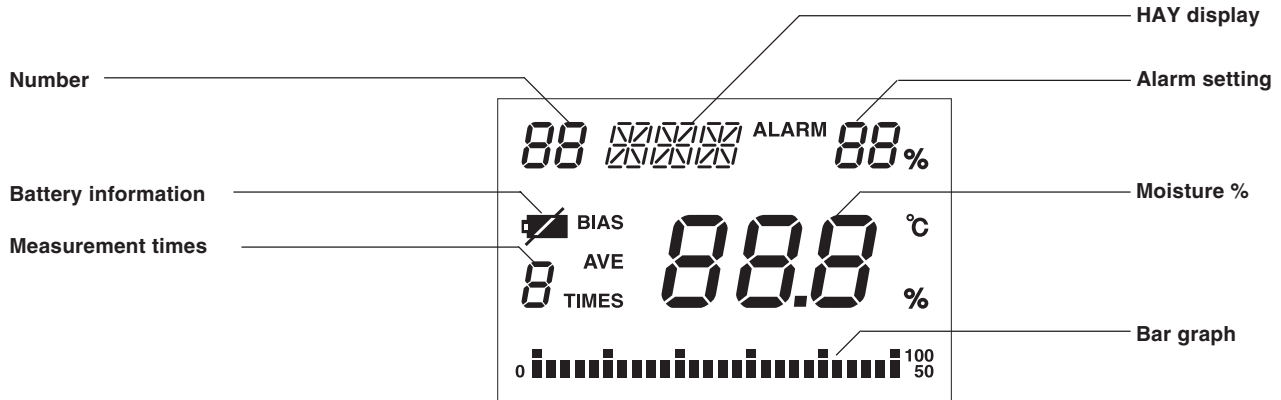

5. HOW TO USE THE INSTRUMENT

5-1. Preparation for measurement

- (1) Install the six AA alkaline batteries in the battery compartment on the back of the instrument. Remove the battery compartment door and install the batteries. Take care not to reverse the polarity (+ & -) of the batteries. Replace the cover.
- **When the batteries are worn,  will blink on the display screen.**
Change all batteries at the same time.
- (2) Connect the probe firmly to the body. Turn the lock ring at the base of the probe clockwise to secure the sensor probe.
 - (3) Take off the probe cap.

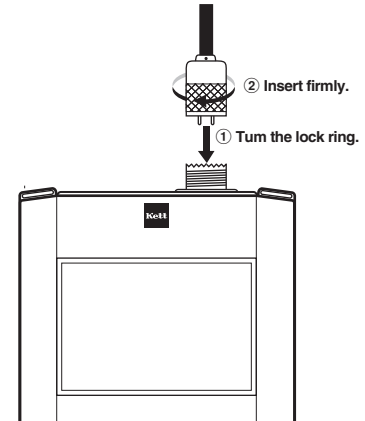

5-2. How to measure

(1) Press the **ON/OFF** key to turn the instrument power on. For 3 seconds the LCD will show all the letters and signs on it. After that "HAY", "TIMES" and "%" will be displayed.

- If the LCD wouldn't start up as described here, there might be an error occurring in the instrument. Refer to "6. Error display" .

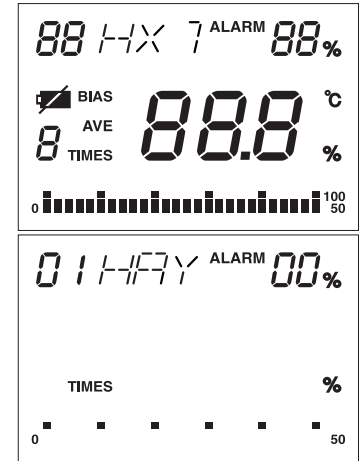

(2) Insert the probe in the hay.



- The top of the probe has a sharp edge. Take good care not to damage anything while measuring. Be sure to put the cap on after use.

(3) Press the **MEA 7** or **MEA 9** key, the decimal point will blink.

In about 3 seconds after a short beep, "Measurement Times", "Moisture %" and "Bar Graph" will be displayed.

- **The bar graph increment is 2%, and capable of displaying 50% at maximum.**
- **If the measurement result is out of the range, "HI" for exceeding and "LO" for lower than will be displayed.**

(4) Pull the probe out of the hay. The last moisture % will remain displayed. To continue the measurement, insert the probe again in the hay, as per (2) above.

Turn the power off pressing the **ON/OFF** key after you have finished measurement.

- **This instrument turns the power off automatically after being left unused for 5 minutes.**



❖  shows that either numbers or marks enclosed are blinking.

5-3. Precautions for measurement

- (1) Insert the probe at the outer surface of the hay roll.
Other ways of measurement may result in errors.

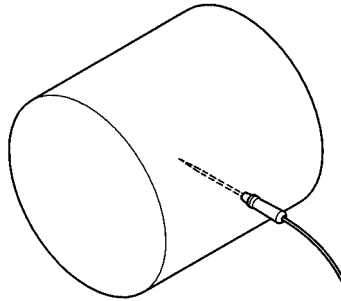

- (2) If it is difficult to insert, try other angles or make a hole with a sharp stick before inserting the probe.

5-4. Display of the average

After measurement has been done 2~9 times, you can display the average by pressing the **AVERAGE** key. The key will display "AVE" "Calculated average" and "Measurement times". After 9 times the "Measurement times" display will return to 1.

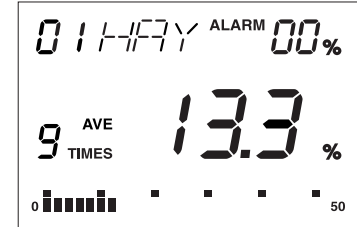

5-5. How to set Continuous Measurement mode

In this mode, you don't have to press the  or the  key every time for measurement.

(1) To set the continuous measurement mode;

After the operation of "5-2 Measurement (3)", press the  key, the decimal point will blink and the bar graph will appear. "LO" will be displayed if the probe is off the sample or the sample moisture is lower than the measurement range.

(2) To release the continuous measurement mode;

Press the  key for more than 2 seconds until a short beep is heard, the display will be off for a moment and return to the normal measurement mode when the pressed key is released.

-  **Turning off the instrument power will switch off the continuous measurement mode.**
- **Continuous mode consumes battery power faster. A new set of batteries will last about 24 hours in this mode at 20°C (68°F).**

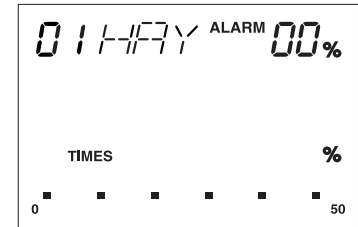

❖  shows that either numbers or marks enclosed are blinking.

5-6. How to correct the moisture % display

The calibration of the instrument is a statistically calculated correlation of the dry process measurement data and the corresponding electric resistance. However the measurement results may differ from the actual moisture, being affected by many aspects of the hay and the environment at the measurement site. In such cases, the moisture % display can accept a bias correction (−9.9~9.9%) described as follows.

- (1) Press the **BIAS** key.

"BIAS" on the display will blink and display the corrected value which was last entered. 0.0% is the default value.



- (2) Enter the correction value.

Enter 2-digit value. Press the **2** and the **ALARM 0** key for 2.0% for instance. If entering a minus correction press the **-** key before entering the numeric value.



- (3) Press the **MEA 7** or the **MEA 9** key to start the corrected measurement.

- "BIAS" will be displayed during measurement.

❖  shows that either numbers or marks enclosed are blinking.

5-7. How to set the alarm

The upper moisture limit alarm can be set. A series of short beep sounds let you know the sample is over the limit.

- (1) Press the  key.

The number to the right of "ALARM" will blink.

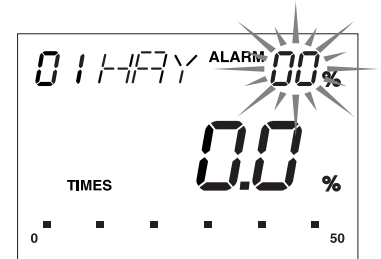

- (2) Enter the limit value.

Enter 2-digit number of the limit. Press the  and

 key to enter 20% for instance.

- (3) Press the  or the  key to start the measurement.



- To release the alarm setting, enter "0.0%".

❖  shows that either numbers or marks enclosed are blinking.

6. ERROR DISPLAY

If an error has occurred in the instrument or in the measurement conditions, either of the following messages will appear for 4 seconds before turning the power off automatically.

(1) The temperature sensor has an error. Call for repair.



001

(2) The electric circuit for measuring moisture has an error. Call for repair.



002

- (3) The instrument temperature is -5°C (23°F) or lower. Warm the instrument up to the usable ambient temperature range $0\text{--}40^{\circ}\text{C}$ ($32\text{--}104^{\circ}\text{F}$).

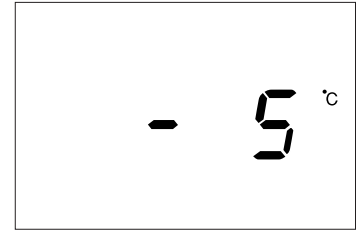

- (4) The instrument temperature is 50°C (122°F) or higher. Cool down the instrument to the usable ambient temperature range $0\text{--}40^{\circ}\text{C}$ ($32\text{--}104^{\circ}\text{F}$).



MEMO

The Kett logo consists of the word "Kett" in a white, bold, sans-serif font, positioned inside a dark gray square.

Kett

KETT ELECTRIC LABORATORY

1-8-1 Minami-Magome Ota-Ku, Tokyo 143-8507 Japan

Tel.+81-3-3776-1121 Fax.+81-3-3772-3001

URL <http://www.kett.co.jp/> E-mail overseas@kett.co.jp