

Single Kernel Grain Moisture Tester

PQ-520

(type PQ-5203-1)

The Kett logo consists of the word "Kett" in a white, sans-serif font, centered within a dark gray square.

Kett

Operating Instructions

Single Kernel Grain Moisture Tester Safety Precautions

Not following the safety precautions could cause an accident resulting in injury.

This product has a drive motor drive that can potentially cause injury.

Please follow the safety precautions



Read the precautions described in these operating instructions.

Do not use this product when broken

When this product is broken or malfunctioning, contact the Kett service center.

Understand the warning symbols

In order to prevent accidents due to improper use, the following warning symbols are provided in the instructions and on the product. The explanation for each symbol is listed below:

	Danger	This symbol indicates that the user risks serious injury or death if the warning is ignored and the product is operated incorrectly.
	Warning	This symbol indicates that the user risks sustaining an injury or bodily harm if the warning is ignored and the product is operated incorrectly.
	Note	This symbol indicates that the following instructions should be read and understood in order to use the unit safely and properly.

Emergency symbols



Fire



Electrical Shock

Prohibited action symbols



Prohibited



No disassembly



No water

Correct usage symbols













Required



Unplug Cord



Connect to Ground

 Danger	
 	Do not use any voltage other than the determined power supply voltage. Excessive voltage can cause damage or fire.
 	Be sure to ground the electrical power cord. When the electrical outlet is a two-prong type, please connect the green-colored ground line protruding from the adapter to the ground. When using a three-prong type outlet, grounding is automatic. Electrical shock may occur if the product isn't grounded.
 	When replacing the fuse, use the designated capacity and type, and unplug the product from the electrical outlet. Use of a non-designated fuse may result in the risk of fire.
 	Do not disassemble or modify the grain moisture tester. Such actions may result in breakage, electrical shock, injury, etc. If the product is thought to be malfunctioning, please contact our company's service center.
 	Do not get this product wet. This instrument isn't a waterproof. Water entering the unit may result in electrical shock and malfunction.





 Warning	
	When unplugging the power plug and power cord, make sure to unplug the connector and plug without pulling or yanking on the cord.
	When not using the instrument or when there is lightning, set the power switch to the OFF position and unplug the power cord from the electrical outlet.
	When a dangerous incident occurs (e.g. odor, smoke, fire, etc.), set the power switch to the OFF position and take suitable measures such as disconnecting the power cord from the electrical outlet.
	Do not press the power switch while pressing the operation key. Do not press multiple operation keys simultaneously or press keys other than the specified keys.

Table of Contents

1. Functions and Features	2
2. Specifications.....	3
3. Names of Parts.....	4
4. Preparing for Measurement.....	6
4-1. Connecting the Power Cord	6
4-2. Start-up of Main Unit	6
4-3. Selecting the Measurement Sample.....	7
4-4. Setting the Number of Kernels to Measure.....	7
5. Measurement.....	8
5-1. Loading the Sample	8
5-2. Starting Measurement.....	8
6. Measurement Precautions	10
6-1. Cleaning the Internal Feed Unit	10
6-2. Temperature Correction	11
6-3. Discharge Tray.....	11
7. Printing.....	12
7-1. Setting the Printing Mode.....	12
7-2. Types of Print Modes.....	12
7-3. Sample Print-out.....	13
8. Setting the Time	14
9. Error Messages	15

1. Functions and Features



- **Functions**

This grain moisture tester continuously measures the moisture of a sample one kernel at a time, thus making it possible to accurately determine the moisture distribution of the sample and preventing uneven moisture caused by inadequate drying.

- **Features**

- (1) Simple operation.
- (2) Measurements may be quickly performed.
- (3) The moisture distribution is understood at a glance.
- (4) If the optional printer is connected, the measurement data may be printed.

2. Specifications

Measurement Method	: Electrical resistance
Measurement Target	: Milled rice, Brown rice, Paddy rice, Barley, Wheat, Naked barley
Measurement Ranges	: Milled rice ... 11 - 20% Brown rice ... 11 - 20% Paddy rice ... 11 - 35% Barley ... 10 - 40% Wheat ... 10 - 40% Naked barley ... 10 - 35%
Measurement Time	: Less than 40 seconds per 100 kernels (measurement of brown rice, time for display of average moisture value)
Measurement Precision	: $\pm 0.5\%$ (moisture less than or equal to 20%)
Display Method	: Fluorescent tube display
Contents of Display	: Selected grain type, average moisture value, kernel count, time, moisture distribution (histogram)
Temperature Correction	: Automatic instrument temperature correction using a thermostat
Kernel Count Setting	: 10 to 1,000 kernels (customer selected)
Temperature Range	: 5 to 40°C, 85% relative humidity or less (without condensation)
Output	: RS-232C interface (for printer), USB (for PC)
Power Source	: AC 100-120V (50/60 Hz) • Power cord A (Flat blade attachment plug, Type A-1) : AC 200-240V (50/60 Hz) • Power cord B (Round pin attachment plug, Type C-4)
Electrical Consumption	: Maximum of 76W
Dimensions	: 320 (W) × 254 (D) × 382 (H) mm
Weight	: 9.0 kg
Accessories	: Scoop, Tweezers, Power cord A (100-120V w/Conversion Adapter) or Power cord B (200-240V)
Options	: Printer (VZ-330 w/VZC-14 cable) Data logger software (PDL-01)

3. Names of Parts

Main Unit

[Front]

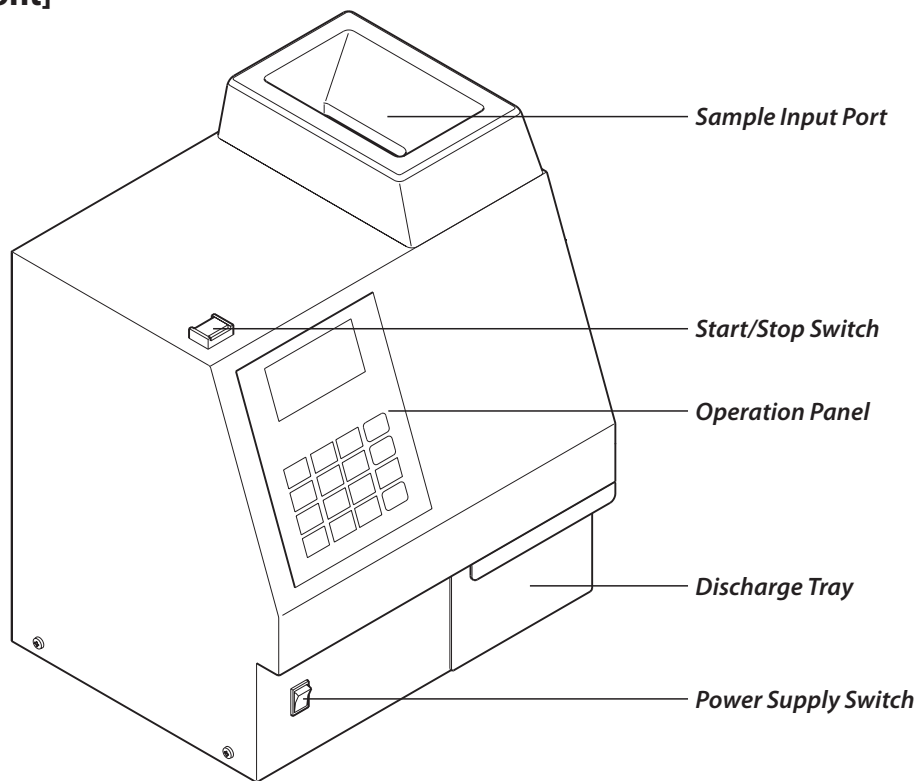

[Back]

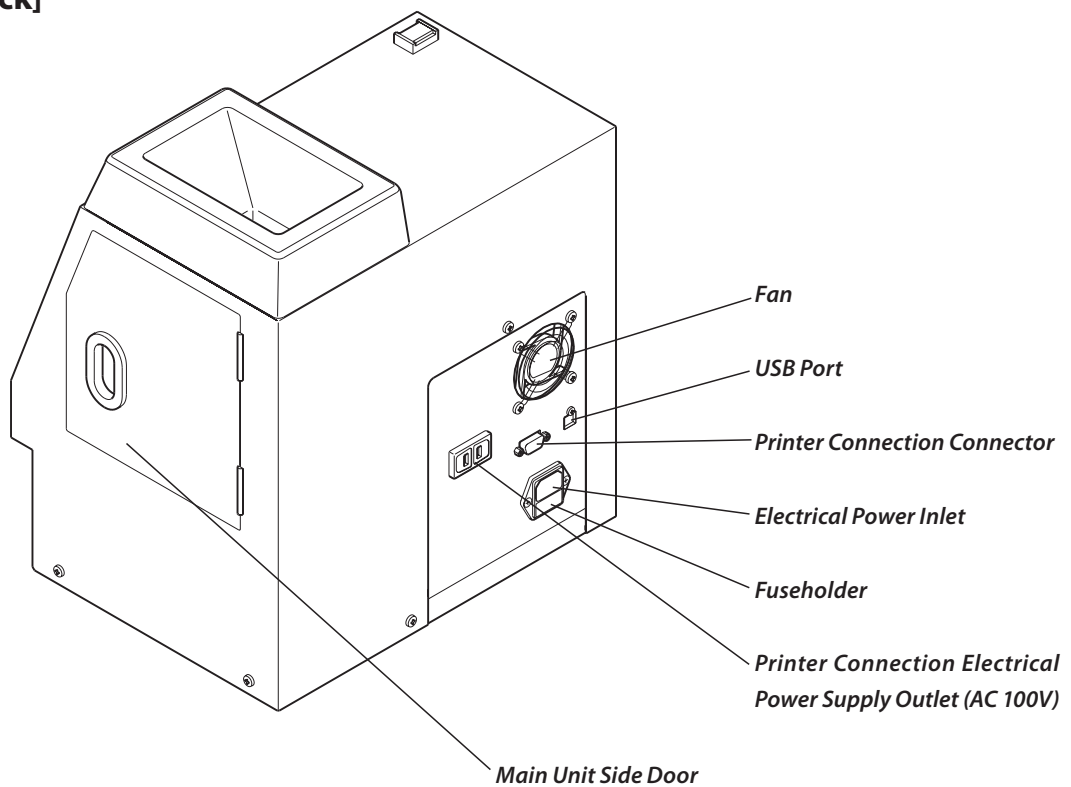

[Internal Feed Unit Configuration]

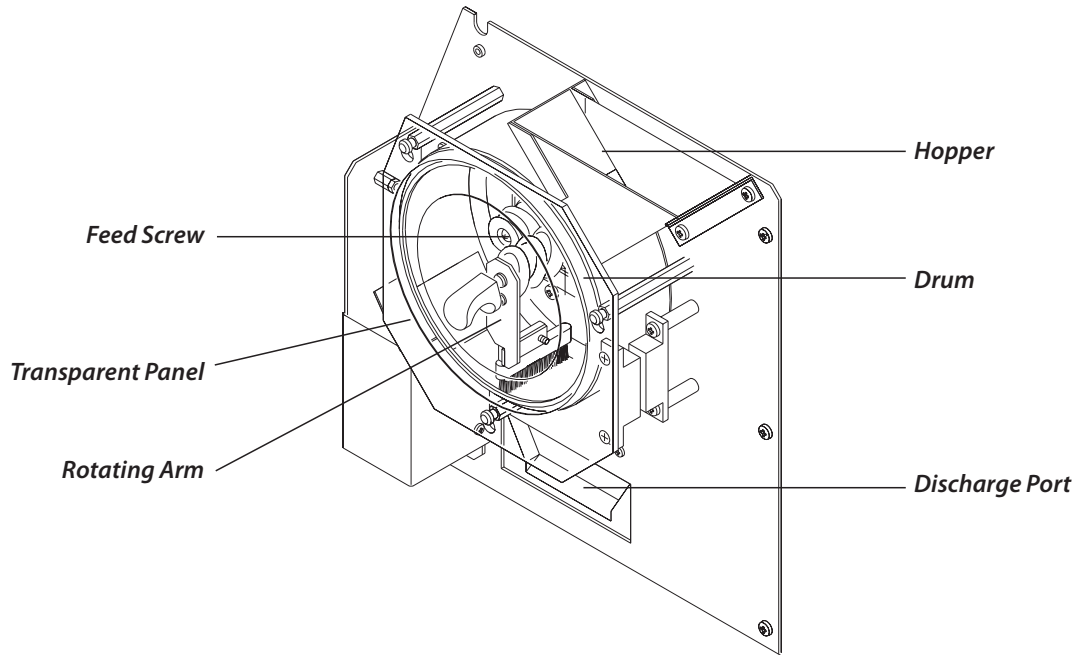

Accessories

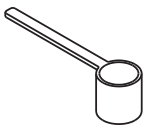

Scoop

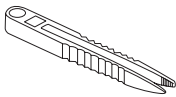

Tweezers

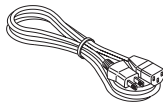

Power Cord A
(100V-120V)

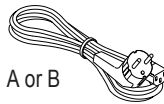

Power Cord B
(200V-240V)

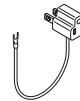

Power Plug Conversion Adapter
(It is attached for Power cord A
(for 100V-120V uses) only.)

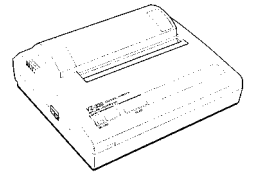

Printer VZ-330
(w/ Printer Connector
Cable VZC-14)

Operation Keys

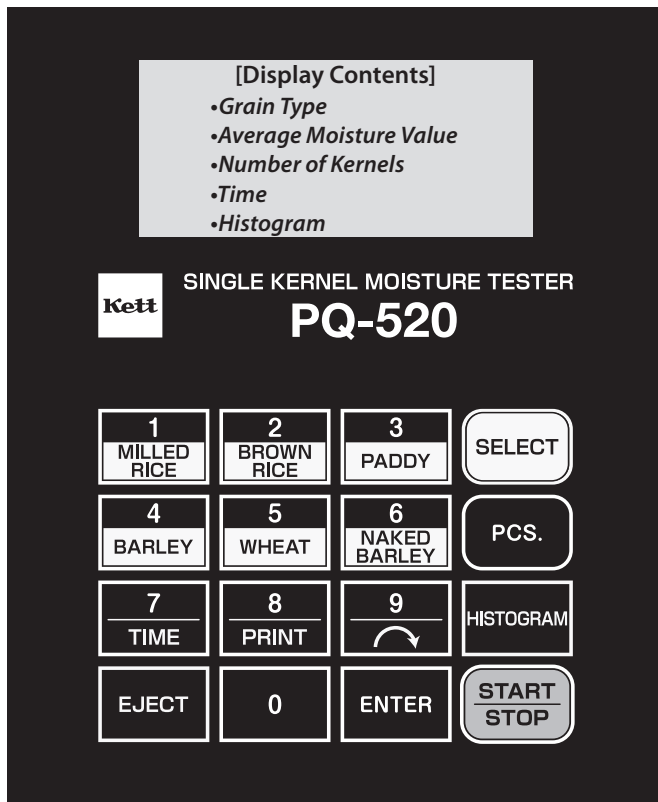

Keys	Function
	Displays or sets the time
	Switch to print mode setting
	Turn the rotating arm
	Discharge the simple contained in the drum
	Enter settings
	Select type of grain to be measured
	Set number of kernels
	Use histogram to display the moisture distribution
	Start or stop measurement

4. Preparing for Measurement

After opening the box, please open the side door of the main unit and remove the lock fitting used for shipment (rubber ring).

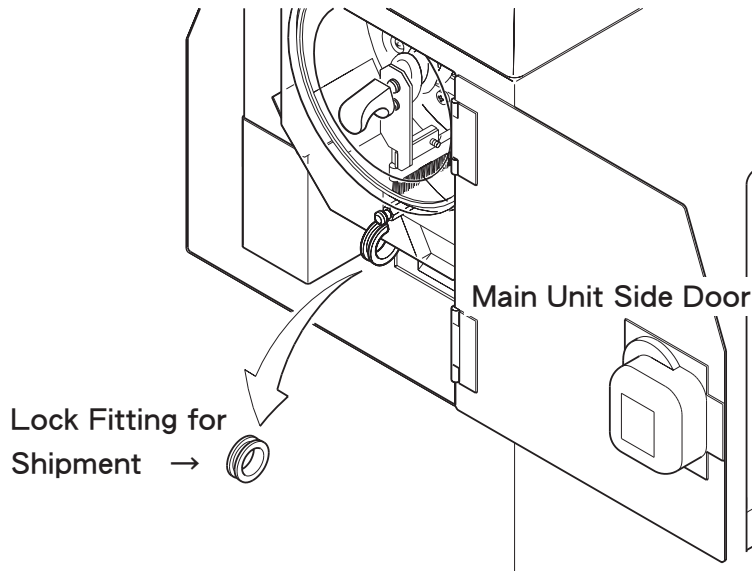

4-1. Connecting the Power Cord

[Caution] Power supply voltage may be different when using this product in other countries. Please only use a power cord designed for your country.

- (1) Insert the power cord into the power supply connector on the rear side of the main unit.
- (2) If the power supply is a three-prong plug 100V-120V outlet, insert the power cord into VAC outlet. (See the right fig and in case of 100V-120V uses with blade plug condition.)

Connect the included power plug conversion adapter into the power cord first, then plug the cord into a 100V-120V power outlet. Next, connect the ground wire on the power cord to the ground.

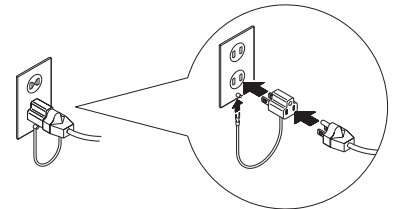

[Caution] 200V-240V outlet is used, power cord B should be used.

[Caution] If the power supply is 200V-240V with flat blade plug, the conversion adapter should be prepared by yourself.

[Caution] If the power supply is 100V-120V with round pin plug, the conversion adapter should be prepared by yourself.

4-2. Start-up of Main Unit

Turn the electrical power switch at the front of the main unit ON.

A buzzer will sound, the internal feed screw will rotate to remove residual samples within the interior, and the shutters will open and close. The display will change to the pre-measurement state.

Power ON

Kett





Pre-Measurement

PADDY

100PCS

4-3. Selecting the Measurement Sample

Example : Selection of milled rice (#1).

- (1) Press the  key and the grain type display with blink.
- (2) When the  key is pressed, the display changes from PADDY to MILLED RICE.

Measurable Samples Include:







- (3) Press the  key and the grain type is set to MILLED RICE. The display enters the pre-measurement state.

4-4. Setting the Number of Kernels to Measure

The number of measured kernels may be set within the range of 10 to 1,000 kernels.

- * **Note 1 :** This is set to 100 kernels at the time of shipment of the unit.
- * **Note 2 :** If the number is set to less than 10 kernels, the setting will become 10 kernels.
- * **Note 3 :** The number of kernels that can be set ranges from 10 to 1,000

[Example : Setting to 150 kernels]

- (1) When the  key is pressed, the grain number display blinks.
- (2) Press the key sequence   .
- (3) When the  key is pressed, the number of kernels is set.

Selection of Measurement Sample



Selection of Milled Rice (#1)



Milled Rice (#1) Setting Complete



Selection of Number of Kernels



Set to 150 Kernels



Setting of 150 Kernels Complete



5. Measurement

5-1. Loading the Sample

Through the sample input port, pour the sample into the hopper.

When a single spoonful is sampled using the scoop accessory, the estimated number of kernels which will be measured (13 to 18% moisture content) is listed below:

Grain Type	Milled Rice	Brown Rice	Paddy Rice	Barley	Wheat	Naked Barley
Kernels	200	180	120	110	120	120

**Note: When the hopper empties during measurement, please add more samples to complete the test.*

5-2. Starting Measurement

- (1) When the "start/stop" switch at the upper left of the main unit or the



key is pressed, the display changes as indicated on the right.

Before Measurement



Measurement

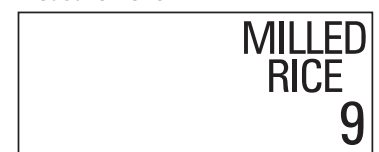

**Note 1: Measurement is not possible without proper placement of the main unit internal transparent panel. If "PANEL" is displayed, please check the transparent panel.*



**Note 2: The motor stops for safety when the transparent panel is opened during measurement. If the transparent panel is again attached and the "start/stop" switch is pressed, motor rotation will take place, and measurement will continue.*

- (2) When measurement ends, the average moisture value is displayed.

After Measurement

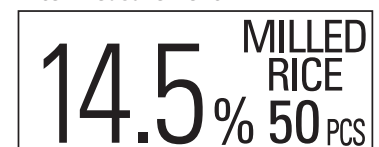

- (3) Sample remaining within the interior is automatically discharged, and when the motor stops, the buzzer sounds. After motor stoppage, when the  key is pressed, the moisture distribution of the measured sample is displayed with a histogram.

Histogram Display Range

Milled Rice / Brown Rice	Paddy Rice / Barley / Wheat / Naked Barley
10 to 20%	10 to 40%

Milled Rice, Brown Rice

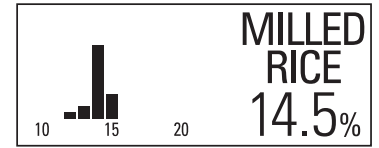

Paddy Rice, Barley, Wheat, Naked Barley

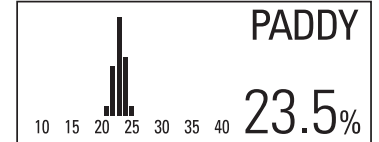

- (4) When the start/stop switch at the upper left of the main unit or the  key is pressed, the next measurement may be made.

*** Note 1:** *Even if the printer is still printing, as long as the motor has stopped, the next measurement may start.*

*** Note 2:** *To stop a test in the middle of a measurement, please press the "start/stop" switch. The average moisture value for the number of kernels measured up to that point will be displayed.*

*** Note 3:** *When kernels have not been counted within 30 or more seconds, the buzzer will sound and "POURING" will be displayed. Since the sample may have run out, or the sample may have plugged the screw feed, please check the interior of the drum. This display will disappear after sample is again loaded and the count starts.*



6. Measurement Precautions

6-1. Cleaning the Internal Feed Unit



Allowing the sample to remain in the internal feed unit results in damage and reduced measurement efficiency. Please clean the internals as needed and as described below.

- (1) Open the side door of the main unit and check whether samples remain in the feed unit (samples remain on the screw).

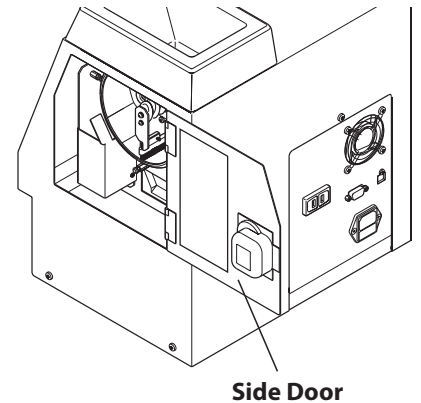

- (2) The cleaning operation is difficult when the rotation arm is at the upper part of the drum.

Press the  key in order to move the rotation arm to the lower part of the drum.

Press the  key again once the rotation arm is positioned at the lower part of the drum. Rotation stops after pressing the key. Rotation stops automatically after 10 seconds.

*** Note : For safety, the motor will not rotate when the transparent panel is not installed.**

Also, if the transparent panel is lifted when the motor is rotating, rotation will stop.

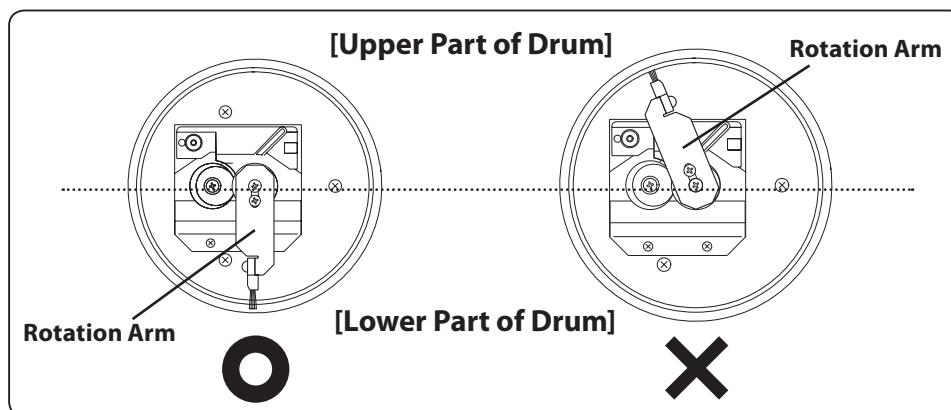

- (3) Lift the lug of the internal transparent panel, and pull the internal panel out to the front.

*** Note : Breakage may result if the transparent panel is forcefully pulled out.**

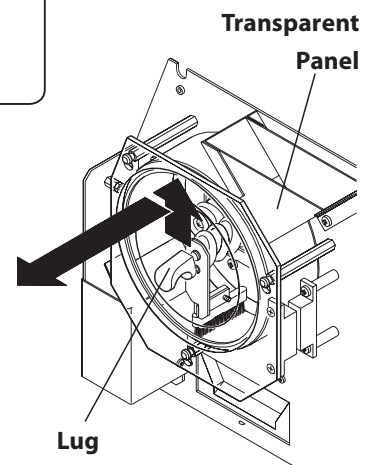

- (4) Rotate the mounting screw and remove the screw cover to the front.

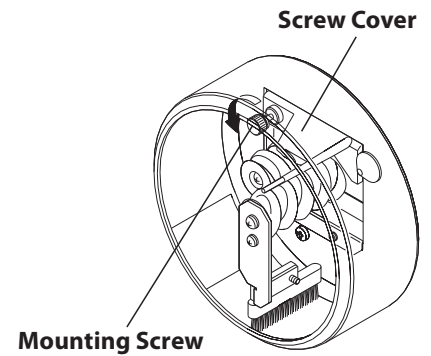

- (5) Since the internal feed unit is visible, clean out trash or the remaining sample.
(This operation is easily performed using the accessory tweezers).

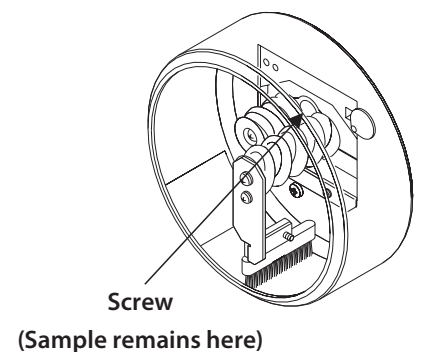

- (6) After cleaning has ended, assemble by following steps (4), (3), and (1).

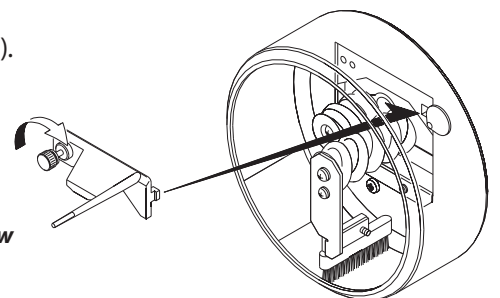

*** Note:** *During attachment of the screw cover, rotate the mounting screw after pulling on the right edge part lug.*

6-2. Temperature Correction



The temperature sensor is attached to the interior of the instrument. Temperature compensation is automatically performed. However, when the difference between the temperature of the grain and the temperature of the machine is too large, temperature compensation will not work and the error between the real moisture value and reported value can become very large. In order to get an accurate measurement, make sure that the temperatures of the grain and machine are sufficiently close before measurement.

6-3. Discharge Tray







Please discard samples that have accumulated in the discharge tray before the tray becomes full. Measurement while the discharge tray remains full results in erroneous measurement and damage.

7. Printing

By connecting an optional printer (VZ-330) to this unit, it is possible to print out the results of measurement. Types of printing will be explained here. Please refer to the separate publication "Printer VZ-330 Operating Manual" for detailed operation of the printer.

It is also possible to use optional data logging software (PDL-01) and to send the results of measurement from the USB port to a personal computer. Please refer to the separate publication "Data Logger Software PDL-01 Operating Manual" for detailed operation of the software.

7-1. Setting the Printing Mode

- (1) Print mode may be set during pre-measurement (display of the set number of kernels).
- (2) During the pre-measurement state press the  key.
- (3) Referring to "7.2 Types of print modes," select the print mode, and press the 1 through 3 number keys.   
- (4) When the  key is pressed, the print mode is confirmed, and the unit returns to the pre-measurement state.

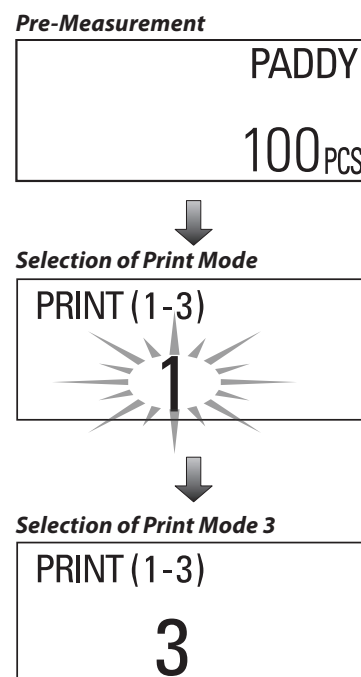

7-2. Types of Print Modes

There are three types of print modes, as listed below.

Mode	Print Details
1	yyyy/mm/dd, type of grain, no. of measured kernels, average moisture, standard deviation, temperature
2	yyyy/mm/dd, type of grain, no. of measured kernels, average moisture, standard deviation, temperature, histogram
3	yyyy/mm/dd, type of grain, no. of measured kernels, average moisture, standard deviation, temperature, histogram, total moisture data

* Note : The unit is initially set to "print mode 1" for shipment.

7-3. Sample Print-out

Print Mode 1

```

=====
PQ520                      Ver1.0
TIME                        : 9:48
DATE                        : 12/06/05

GRAIN                       : M.RICE
NUMBER OF KERNELS          : 100 PCS.
AVERAGE                    : 14.5 %
STANDARD DEVIATION         : 0.43
TEMP.                       : 26.8 °C
=====
    
```

Print Mode 2

```

=====
PQ520                      Ver1.0
TIME                        : 9:48
DATE                        : 12/06/05

GRAIN                       : M.RICE
NUMBER OF KERNELS          : 100 PCS.
AVERAGE                    : 14.5 %
STANDARD DEVIATION         : 0.43
TEMP.                       : 26.8 °C
=====

-----HISTOGRAM-----
      0          30          60
      |-----|
12.5% █ 1
13.0% 0
13.5% █ 7
14.0% █ 32
14.5% █ 48
15.0% █ 11
15.5% █ 1
=====
    
```

Kernel count scale of the histogram

Print Mode 3

```

=====
PQ520                      Ver1.0
TIME                        : 9:48
DATE                        : 12/06/05

GRAIN                       : M.RICE
NUMBER OF KERNELS          : 100 PCS.
AVERAGE                    : 14.5 %
STANDARD DEVIATION         : 0.43
TEMP.                       : 26.8 °C
=====

-----HISTOGRAM-----
      0          30          60
      |-----|
12.5% █ 1
13.0% 0
13.5% █ 7
14.0% █ 32
14.5% █ 48
15.0% █ 11
15.5% █ 1
=====

14.5 15.2 14.3 13.9 14.7 14.6
14.1 13.5 14.6 14.7 14.3 14.2
14.2 14.9 14.5 14.0 14.9 14.8
14.9 14.9 15.0 14.4 14.6 14.6
14.6 14.5 15.0 14.7 14.4 14.0
14.7 14.7 14.7 14.2 14.4 14.2
15.2 14.5 14.3 14.7 14.2 14.8
15.0 14.4 14.2 13.6 14.6 14.5
14.6 14.7 14.9 15.0 14.1 14.6
14.5 15.1 13.6 14.4 14.8 13.6
14.8 14.3 14.3 14.7 14.7 14.8
14.5 14.8 15.0 14.3 15.1 14.0
14.7 14.7 14.3 14.1 14.6 14.7
14.9 14.2 15.1 14.1 15.6 14.8
14.5 14.1 14.2 14.0 14.6 14.5
13.7 12.9 14.3 14.7 14.7 15.2
14.5 14.3 13.5 14.4
=====
    
```

Kernel count scale of the histogram

Total Moisture Data

8. Setting the Time

When the time has been set, the measurement year, month, and day are correctly printed because of the internal clock. Although the clock is set at the time of shipment, the clock may be reset by the following method:

- (1) The time may be set when in the pre-measurement state (display of the set number of kernels).

Pre-Measurement



PADDY
100 PCS

- (2) When the  key is pressed, the current time is displayed.

When the  key is pressed again, the unit returns to pre-measurement state.

Present Set Time



TIME 00:02:25
2012.08.20

- (3) When setting the time, press the  key.

"Time Setting" state



SET 00:02:25
2012.08.20

- (4) When the year (tens position) flashes, press the desired numerical value and then press the  key.

Year (tens position) flashes



SET 00:02:25
2012.08.20

*** Note : The first two figures of the year ("20") are fixed.**

- (5) When the year (single digit position) flashes, press the desired value and then press the  key.

Year (single digit position) flashes



SET 00:02:25
2012.08.20

- (6) Using the same procedure, enter the "month, day, hour, minute".

- (7) After entering the minute (last position), the time is confirmed by pressing the  key.

The unit returns to the pre-measurement state.

Time Setting Completed



SET 15:20:00
2012.08.31

*** Note : The second count becomes 00 seconds when the time is set.**

9. Error Messages

An error number and error message are displayed when problems occur with the main unit.

Display	Cause	Solution
<div style="border: 1px solid black; padding: 5px; margin-bottom: 5px;">ERR(001)</div> <div style="border: 1px solid black; padding: 5px;">ERR(111)</div>	There is a problem with the electrical circuit.	Repair is needed.
<div style="border: 1px solid black; padding: 5px;">ERR(020)</div>	The temperature sensor temperature is less than or equal to 20°C.	Please operate the instrument within the temperature range of use (5 to 40°C).
<div style="border: 1px solid black; padding: 5px;">ERR(021)</div>	The temperature sensor temperature is greater than or equal to 70°C.	
<div style="border: 1px solid black; padding: 5px;">ERR(022)</div>	The thermistor is malfunctioning.	Repair is needed.
<div style="border: 1px solid black; padding: 5px;">ERR(040)</div>	There is a problem with the electrical circuit.	Repair is needed.
<div style="border: 1px solid black; padding: 5px;">PANEL</div>	The transparent panel isn't attached.	Please remove the main unit transparent panel and then reattach it.
<div style="border: 1px solid black; padding: 5px;">POURING</div>	No sample remains within the drum.	Please load sample, or please check whether there is plugging due to trash.

Problem	Solution
The power does not come on.	Please check the electrical power cord. Please replace the fuse.
Measurement efficiency is poor.	Is the moisture of the measured sample too low? Please clean the unit internals.
The moisture value is high or low.	There is the possibility that the measured sample has not reached the temperature of the unit. Please wait until the sample has reached room temperature.
The time doesn't display.	Repair is needed.
Unable to measure.	Is the unit plugged by trash? Please clean the internals.
The count does not increment.	Is the moisture of the measured sample too low? Please clean the unit internals.

Product After-sale Service

Responsibility for Damage

Our company bears no responsibility whatsoever concerning damage to the customer (i.e. all tangible or intangible losses, such as loss of profit, physical loss, business stoppage, information loss, etc.) due to the use or non-use of this product (including the contained software and data). Moreover, in all cases, the upper limit of damage compensation assumed by our company will correspond to the price paid by the customer for this product.

Periodic Inspection

It is recommended that this instrument undergo periodic inspection in order to check and maintain performance of this product. Although timing will depend on the frequency of use of the instrument, a suitable target for timing is about once per year. Please ask our company or the sales outlet where you ordered this product concerning inspection.

Repair

When there are problems that might indicate a malfunction, please check the related items mentioned in these operating instructions, and please recheck the electrical power supply, connections, operation, etc. When the problems are not fixed please contact our company or the sales outlet where you ordered this product.

Warning

- Reprinting of part or the whole of the contents of this document is strictly forbidden.
- Contents of this document may be revised without prior notification.
- The visual appearance, screen, etc. of the products and accessory items mentioned in this document may differ from those of the actual products and accessory items, although operation and function will not be affected.
- Although the contents of this document were drafted with great care, if you notice unclear points, errors, omissions, etc., please contact our company.
- Regardless of the above warnings, responsibility is not assumed concerning effects resulting from use of this document.



KETT ELECTRIC LABORATORY

1-8-1 Minami-Magome Ota-Ku, Tokyo 143-8507 Japan
Tel. +81-3-3776-1121 Fax. +81-3-3772-3001
URL <http://www.kett.co.jp/> E-mail overseas@kett.co.jp